

**duraflo**<sup>®</sup>

# SQUARE TOP

6050 & 6075  
Roof Vents



- **Easy install rounded posts**
- **Wider usable flange**
- **Reinforced Cap**

**Available in  
50 & 75 Sq. In.**

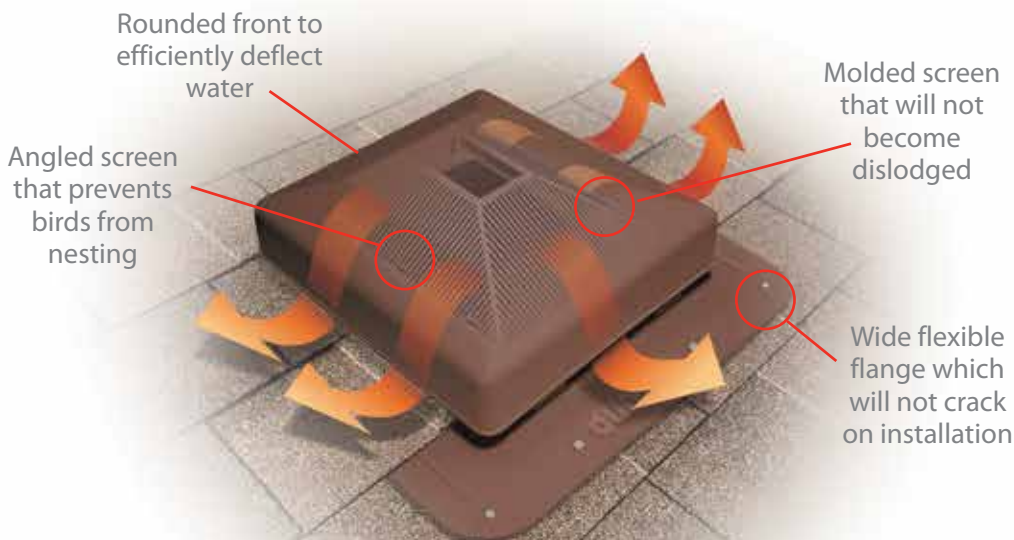

- **Excellent UV Performance**
- Molded screen prevents bird nesting and insect infiltration
- Wide flexible flange for easy installation
- Cold impact resistant to -40
- Low profile styling
- Available in Black, Brown, Grey, and Weatherwood.
- CSA and TDI
- Canadian Patent # 2,597,366



**TDI**  
Texas Department of Insurance

[www.duraflo.com](http://www.duraflo.com)

1-800-461-5300

**canplas**<sup>™</sup>

**duraflo**<sup>®</sup>

# SQUARE TOP

## 6050 & 6075 Roof Vents

50 Sq. In.

75 Sq. In.

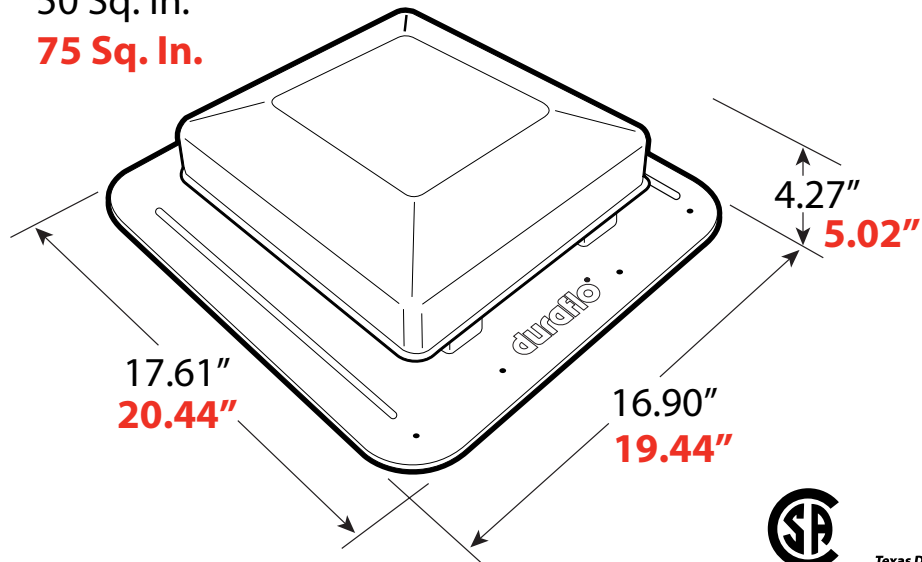

**TDI**  
Texas Department of Insurance

Net Free Area	Description	PART #	Size	CTN. QTY.
50 Sq. In.	Brown	6050BR	16.90" x 17.61" x 4.27"	10
50 Sq. In.	Black	6050BL	16.90" x 17.61" x 4.27"	10
50 Sq. In.	Weatherwood	6050WW	16.90" x 17.61" x 4.27"	10
50 Sq. In.	Grey	6050G	16.90" x 17.61" x 4.27"	10

Net Free Area	Description	PART #	Size	CTN. QTY.
75 Sq. In.	Brown	6075BR	19.44" x 20.44" x 5.02"	5
75 Sq. In.	Black	6075BL	19.44" x 20.44" x 5.02"	5
75 Sq. In.	Weatherwood	6075WW	19.44" x 20.44" x 5.02"	5
75 Sq. In.	Grey	6075G	19.44" x 20.44" x 5.02"	5

**Canplas Industries Ltd.**  
500 Veterans Dr., P.O. Box 1800  
Barrie, Ontario  
Canada L4M 4V3  
Tel: (705) 726-3361  
Fax: (705) 726-2186  
Toll Free: 1-800-461-5300

**duraflo**<sup>®</sup>  
WE KNOW VENTILATION

E-mail: [duraflo@canplas.com](mailto:duraflo@canplas.com)  
[www.duraflo.com](http://www.duraflo.com)

**canplas**<sup>®</sup>