

duraflo[®] PRO50



With the WeatherPRO[®] Series PRO50 you no longer need to worry about extreme weather.

The unique baffle system within the WeatherPRO[®] Series wards off wind driven snow and rain.

- Indicator lines for easy installation
- Eliminates bird nesting
- Cold impact resistant down to -40°
- UV resistant polypropylene
- CSA Approved
- **50 sq. in. of net free area**

CDN. Patent 2,313,601
U.S. Patent 6,767,281



TDI
Texas Department of Insurance

CATEGORY 2
HURRICANE RATED

www.duraflo.com
1-800-461-5300

canplas[®]

Warm moist air exits in a chimney like fashion eliminating shingle stains

Unique baffle system wards off driving snow and blistering rain

Drainage openings allow for water to escape

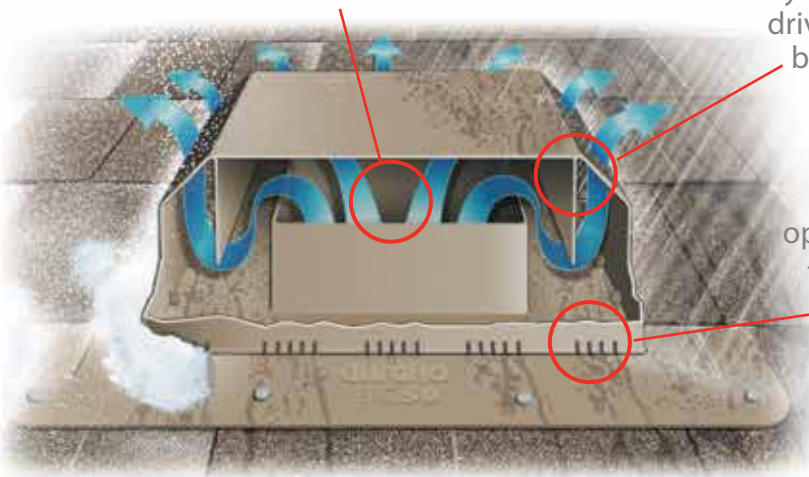

Model: 60PRO50

duraflo[®] PRO50

Description:

- Unique, patented, weather infiltration protection internal baffle system
- Net free venting area of 50 sq-in / 322 sq-cm
- Five PRO50's will ventilate 1000 sq ft of attic space (approx)
- Roof pitch range 2/12 – 14/12
- Injection molded from pure, high grade polypropylene with premium UV inhibitor additives
- Top venting design uses chimney effect to channel moist air away from roof eliminating shingle staining
- Vent cap design with built in weeping holes eliminates bird nesting and water pooling

Standards:

- CSA Approved
- Category 2 Hurricane Rated
- Texas Department of Insurance



Durability:

Engineered to resist denting, peeling, extreme heat and cold impact to -40

Colours:

Black, Brown, Weatherwood, Grey

Weather Protection :

WeatherPRO's patented internal baffles deflect water and snow, allowing it to drain harmlessly out the drainage openings. Designed to allow high airflow while providing excellent defense against weather infiltration.

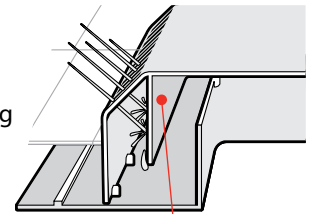

Interior baffle shield

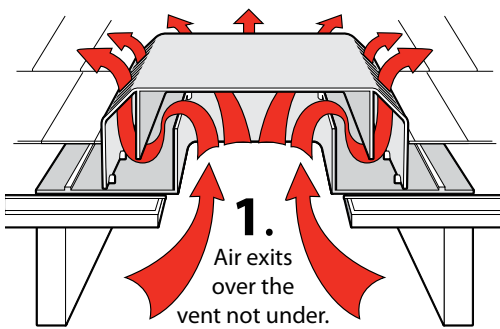
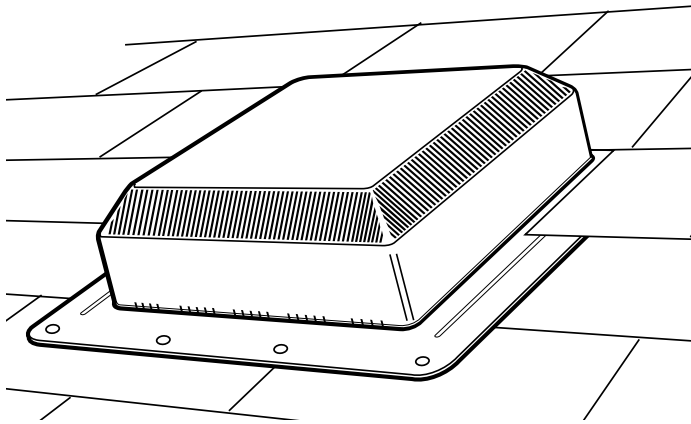

1.

Air exits over the vent not under.

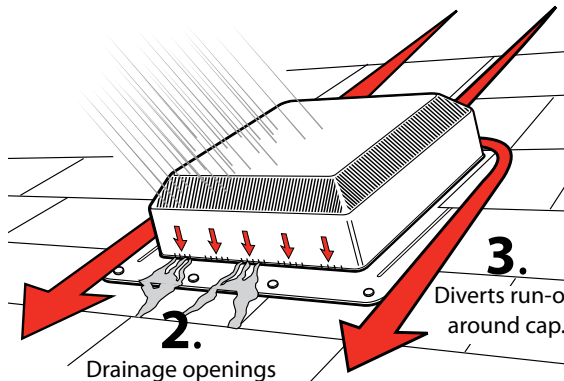

2.

Drainage openings

3.

Diverts run-off around cap.

1. Unique baffle system wards off driving snow and blistering rain while allowing warm moist air to exit in a chimney like fashion eliminating shingle stains.

2. Drainage openings allow for water to escape.

3. PRO50 design diverts water around vent cap. The flat exterior wall acts as second weather defense system while improving airflow.

Dimensions:

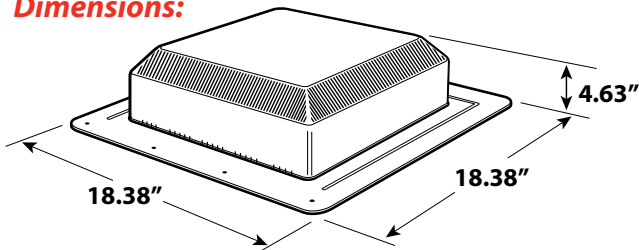

DESCRIPTION	PART #	SIZE	CTN. QTY.
Black	60PRO50BL	18.38" x 18.38" x 4.63"	9
Brown	60PRO50BR	18.38" x 18.38" x 4.63"	9
Grey	60PRO50G	18.38" x 18.38" x 4.63"	9
Weatherwood	60PRO50WW	18.38" x 18.38" x 4.63"	9

Canplas Industries Ltd.
 500 Veterans Dr., P.O. Box 1800
 Barrie, Ontario
 Canada L4M 4V3
 Tel: (705) 726-3361
 Fax: (705) 726-2186
 Toll Free: 1-800-461-5300

duraflo[®]
 WE KNOW VENTILATION

E-mail: duraflo@canplas.com
www.duraflo.com

canplas[®]