

**duraflo**<sup>®</sup>

6065

# SlantBack

Roof Vent



**IMPACT RESISTANT**  
PASSED UL 2218, CLASS 4

HIGHEST RATING POSSIBLE



## The Steep Roof Vent

- 61 sq in. of net free area
- Ideal for steep pitched roofs up to 14/12
- Prevents birds from nesting
- Won't crush, dent or peel
- Cold impact resistant down to -40°
- UV resistant polypropylene
- CSA and TDI approved

Weather Protection for steeper pitched roofs

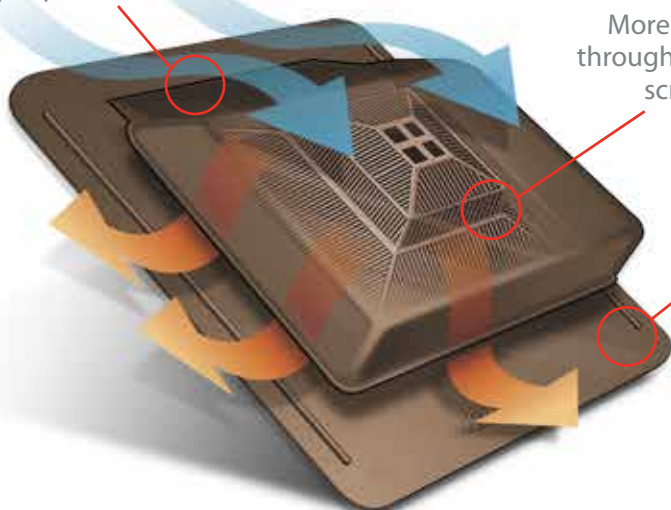

More airflow through stair step screen

Cold impact resistant



**TDI**

Texas Department of Insurance

[www.duraflo.com](http://www.duraflo.com)

1-800-461-5300

**canplas**<sup>™</sup>



**duraflo**<sup>®</sup>

6065  
**SlantBack**  
Roof Vent

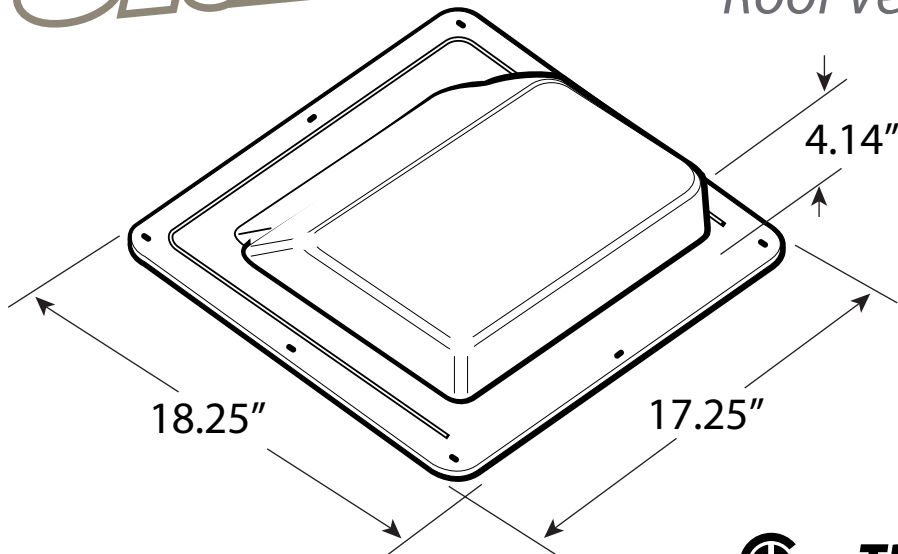

We've taken the 65 Slant Back roof vent that is know and well used in the industry, and made it better.

First, we took out the old fashioned metal screen and added a stair step molded-in grill. This code approved grill with it's unique stair step design allowed us to increase the airflow without having to increase the size of the vent, thus the vent looks better without compromising performance.

Next, we eliminated potential leaks by sonically welding the slant of the cap directly to the roof vent skirt creating a solid, leak-proof bond.

Finally, we made the vent using only the finest, UV and impact resistant resin.

Particularly useful on steeper pitched roofs; the newly redesigned 6065 Slant Back carries on the tradition of quality and innovation you would expect from Duraflo.

Net Free Area	Description	PART #	Size	CTN. QTY.
61 Sq. In.	Black	6065BL	17.25" x 18.25" x 4.14"	12
61 Sq. In.	Brown	6065BR	17.25" x 18.25" x 4.14"	12
61 Sq. In.	Grey	6065G	17.25" x 18.25" x 4.14"	12
61 Sq. In.	Weatherwood	6065WW	17.25" x 18.25" x 4.14"	12

**Canplas Industries Ltd.**  
500 Veterans Dr., P.O. Box 1800  
Barrie, Ontario  
Canada L4M 4V3  
Tel: (705) 726-3361  
Fax: (705) 726-2186  
Toll Free: 1-800-461-5300

**duraflo**<sup>®</sup>  
WE KNOW VENTILATION

E-mail: [duraflo@canplas.com](mailto:duraflo@canplas.com)  
[www.duraflo.com](http://www.duraflo.com)

**canplas**<sup>®</sup>